

## Model A Zenith Carburetor Jet Size & Flow Rates



Jet	Main A-9534	Cap A-9538	Comp A-9575	Idle A-9542
Stamped	19.5, 20	21, 20	19	11, 12
Drill #	#62, #61	#60, #61	#63	#75, #73
Flow Rate CC/Min.	158-164	176-182	152-158	42-52
Thread	5mm-75	5mm-75	5mm-75	5mm-75

Two sizes listed per jet indicate years used (28-29, 30-31)

Flow rates are in CC/Minute (milliliters/min.) with a 36-inch head pressure (i.e. 152-158) and orifice sizes in numbered drill size (i.e. #63).

All original Model A Ford Zenith Carburetor Jets had the orifice size stamped somewhere on the jet, making identification easy. The number stamped on the jet is the orifice size expressed in 0.05 mm increments. For example, a jet marked number '19' has an orifice of  $(19 \times 0.05) = 0.95 \text{ mm.} = 0.037 \text{ in.} = \#63 \text{ drill}$ . No reproduction jets have the jet numbers stamped on them.

### Other Zenith Thread Sizes

Air/Fuel Needle	5mm-75
Secondary Well	3/8-24
Two small holes	#54 drill
Gas Adjusting Valve	1/8-27 NPT
GAV Needle Seat	5mm-75
Drain Plug	3/8-24
Housing Bolt	3/8-24
Mounting Flange	5/16-18
Fuel Inlet	1/2-20
Filter Screen	1/2-20
Float Valve	1/2-20

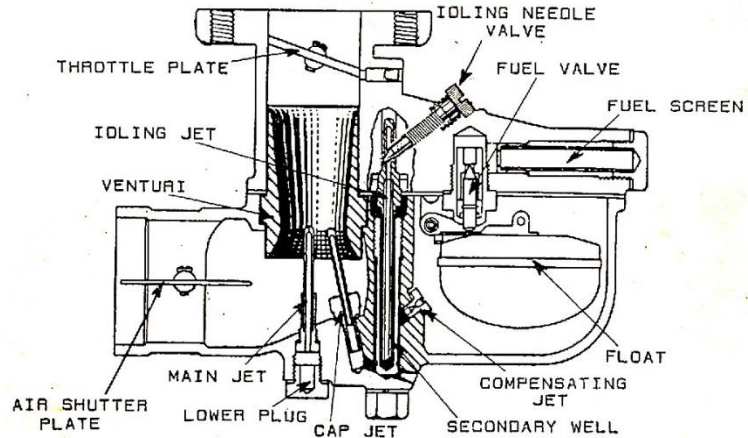

# Hidden Passages

